

SPESIFIKASJON
MAST

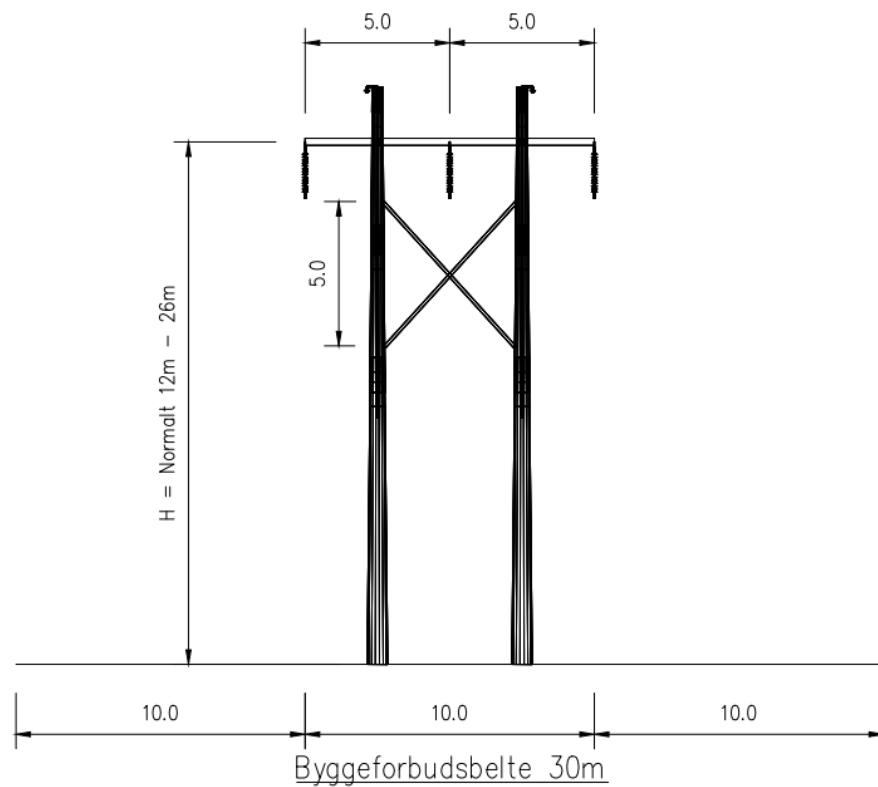

Typer	H-mast med kryssavstivning
Stolper	Komposittstolper
Travers	Aluminium eller stål
Strømførende liner	Feral simplex
Topliner	OPGW og Feral
Isolatorer	Hengekjeder av kompositt eller glass
Systemspenning	132 kV
Byggeforbudsbelte	Normalt 30 m
Høyde	12-26 m høyde på travers
Avstand ytterfase-ytterfase	10 meter

SPESIFIKASJON
MAST

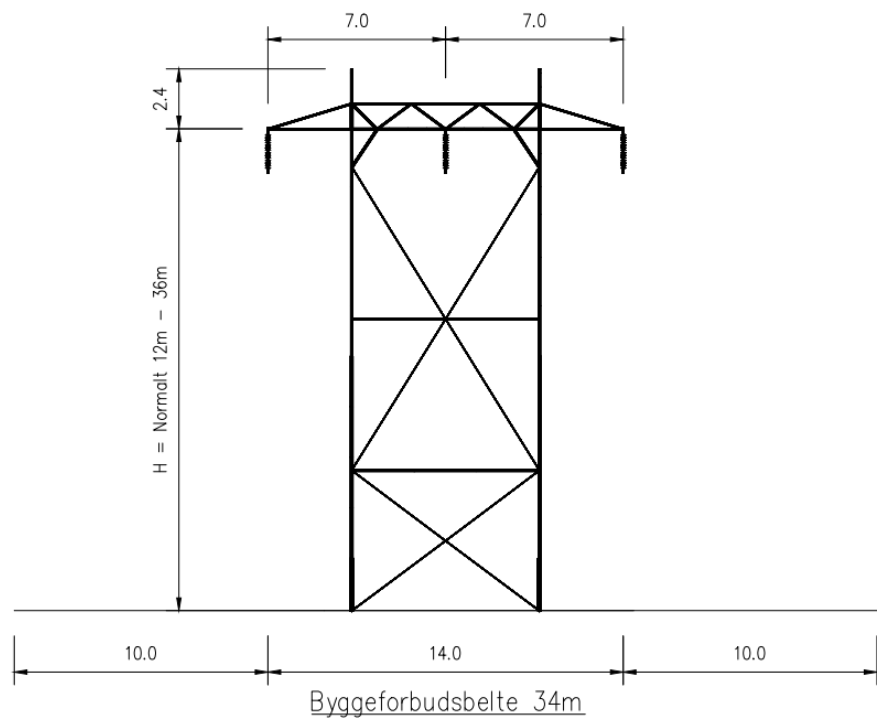

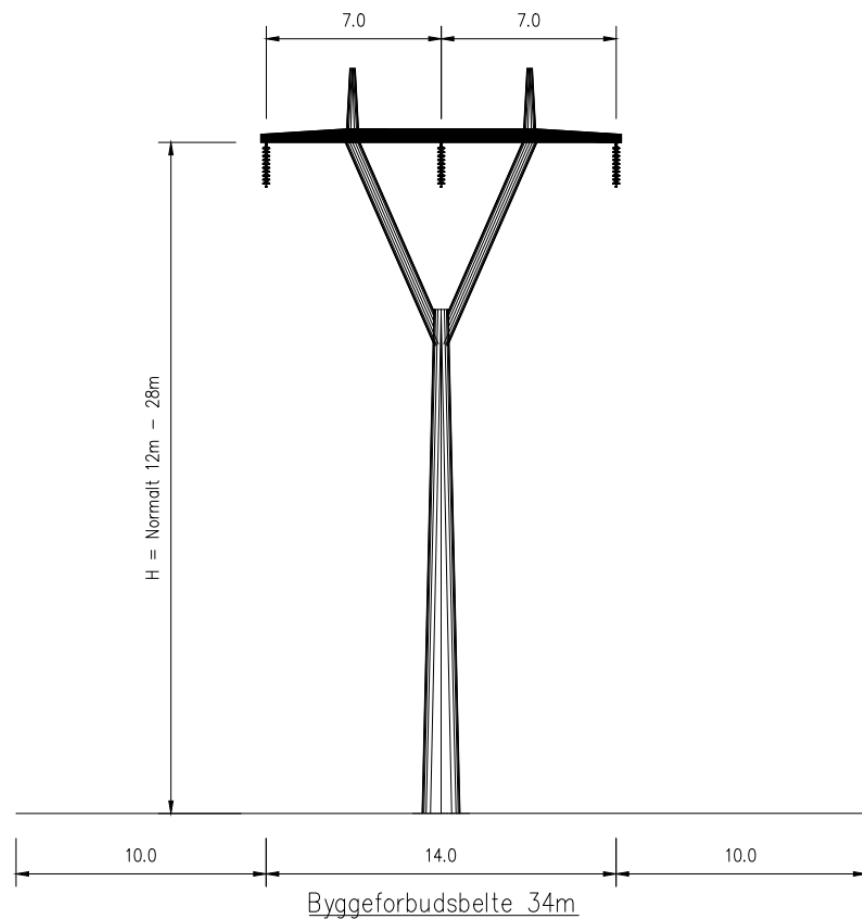

Typer	Portalmast
Mast	Innvendig bardunert
Travers	Stål
Strømførende liner	Feral, simplex
Topliner	OPGW og Feral
Isolatorer	Hengekjeder av kompositt eller glass
Systemspenning	132 kV
Byggeforbudsbelte	Normalt 34 m
Høyde	12-36 m høyde på travers
Avstand ytterfase-ytterfase	14 meter

SPESIFIKASJON
MAST

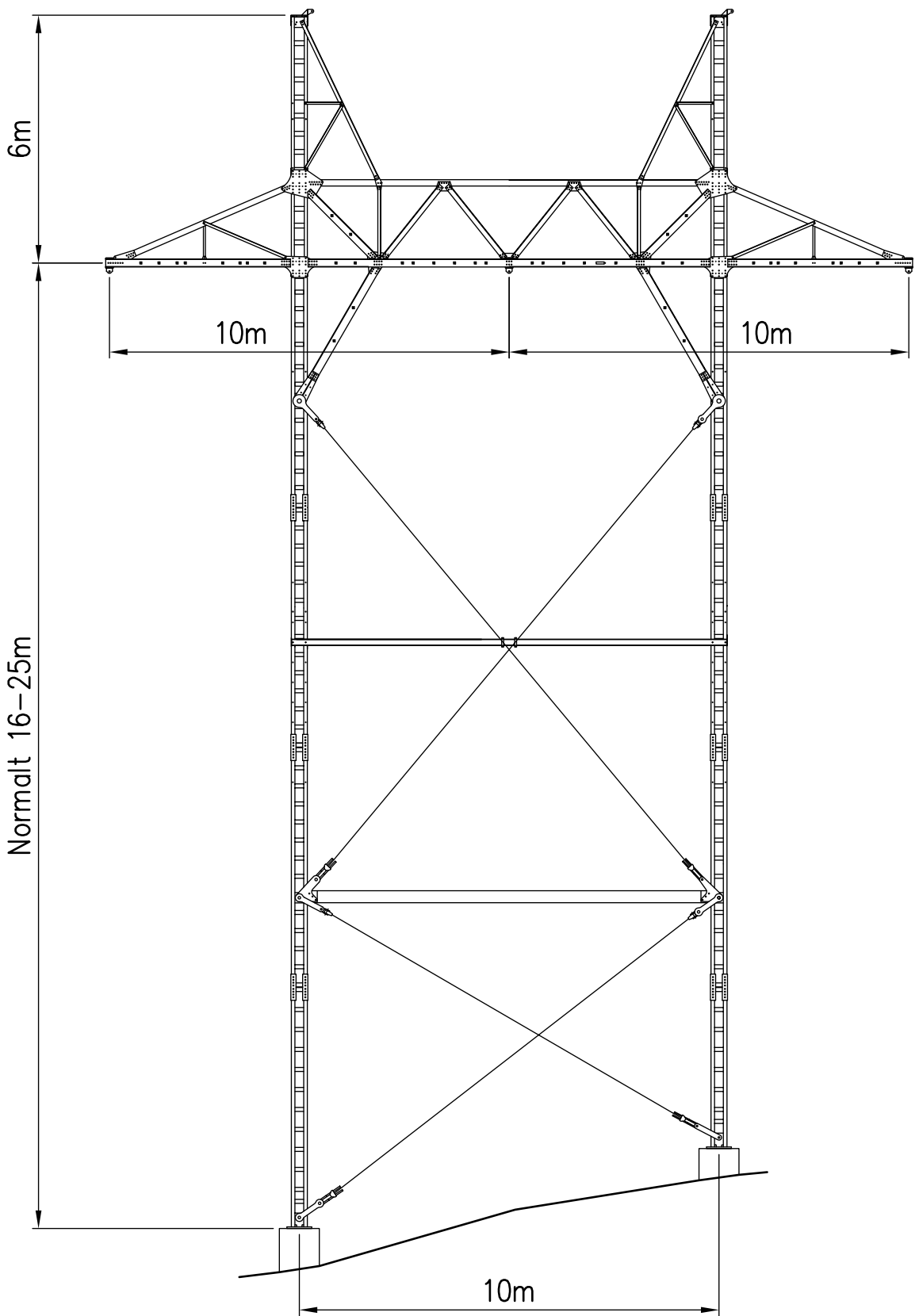

Typen	Rørmast
Mast	Skredmast
Travers	Stål
Strømførende liner	Feral, simplex
Topliner	OPGW og Feral
Isolatorer	Hengekjeder av kompositt eller glass
Systemspenning	132 kV
Byggeforbudsbelte	Normalt 34 m
Høyde	12-28 m høyde på travers
Avstand ytterfase-ytterfase	14 meter



Rev.	Revision			Designed	Checked	Checked	Approved	Date
Project							Scale	-
text	420kV Forankringsmast Faseavstand 10m og benavstand 10m						Designed	IBR
							Checked	
							Checked	
						Contractor (External company or department in Statnett)		Approved
						Technology & Projects		Date
Company's Drawing no.						Replaces Drawing		
Responsible	Executing	Reason for publication			Sheet	Format	Document no	Rev.
TKL	TKL					A4s		

KEEP FROM PUBLIC ACCESS

This document is issued by means of a computerized system. The digitally stored original is electronically approved. The approved document has initials entered in the approved-field. A manual signature is not required.

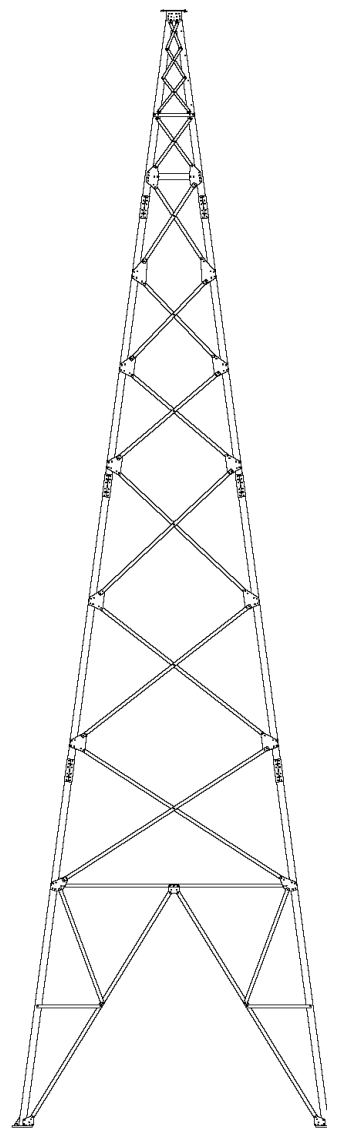
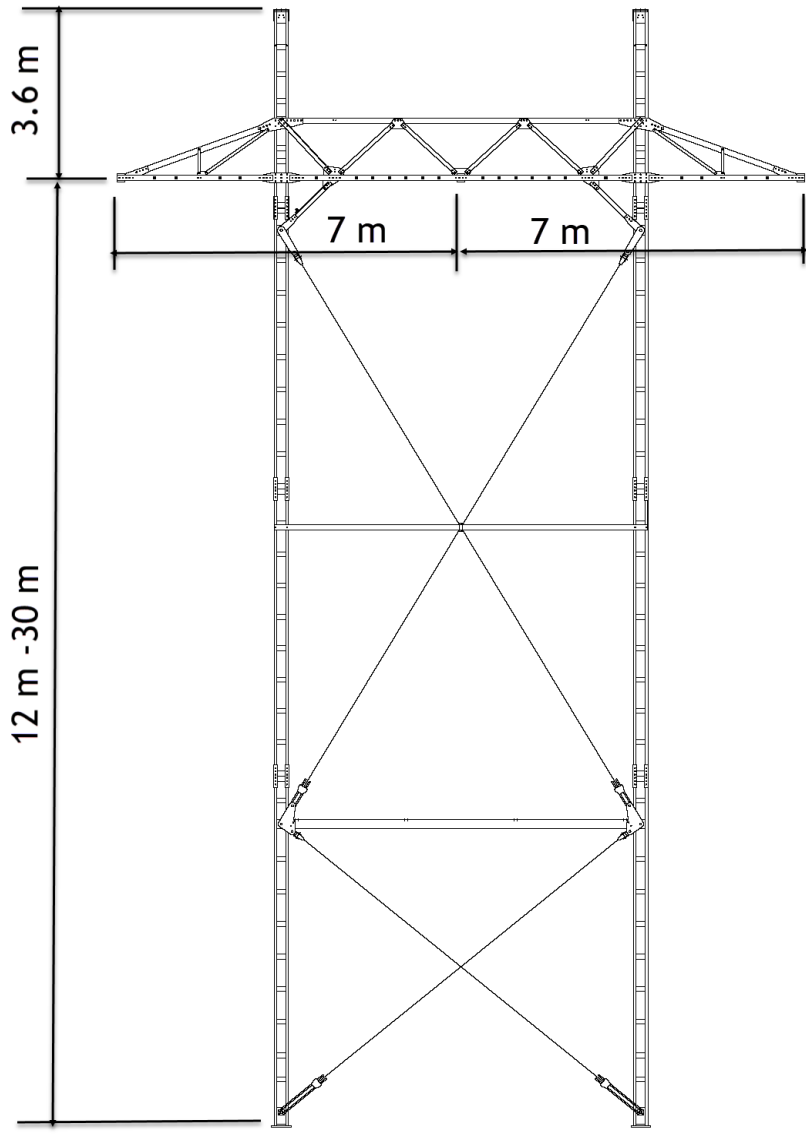

SPESIFIKASJON KOMPOSITTMAST
FORANKRINGSMAST UTVENDIG BARDUNERING

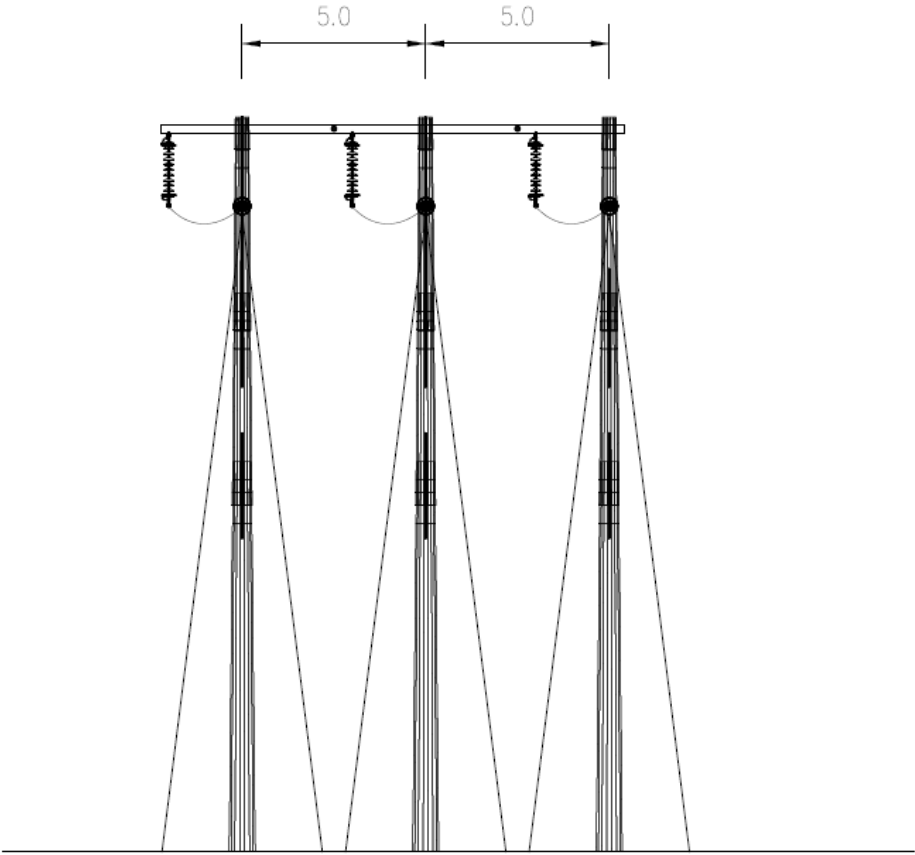

SIDESNITT

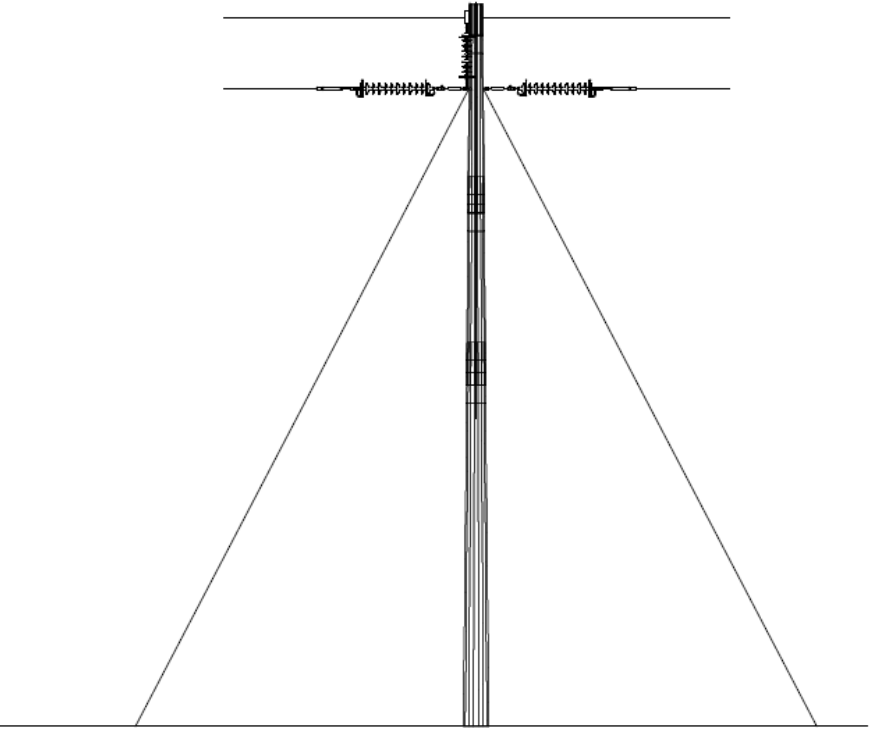

SPESIFIKASJON KOMPOSITTMAST
VINKEL FORANKRINGSMAST UTVENDIG BARDUNERING

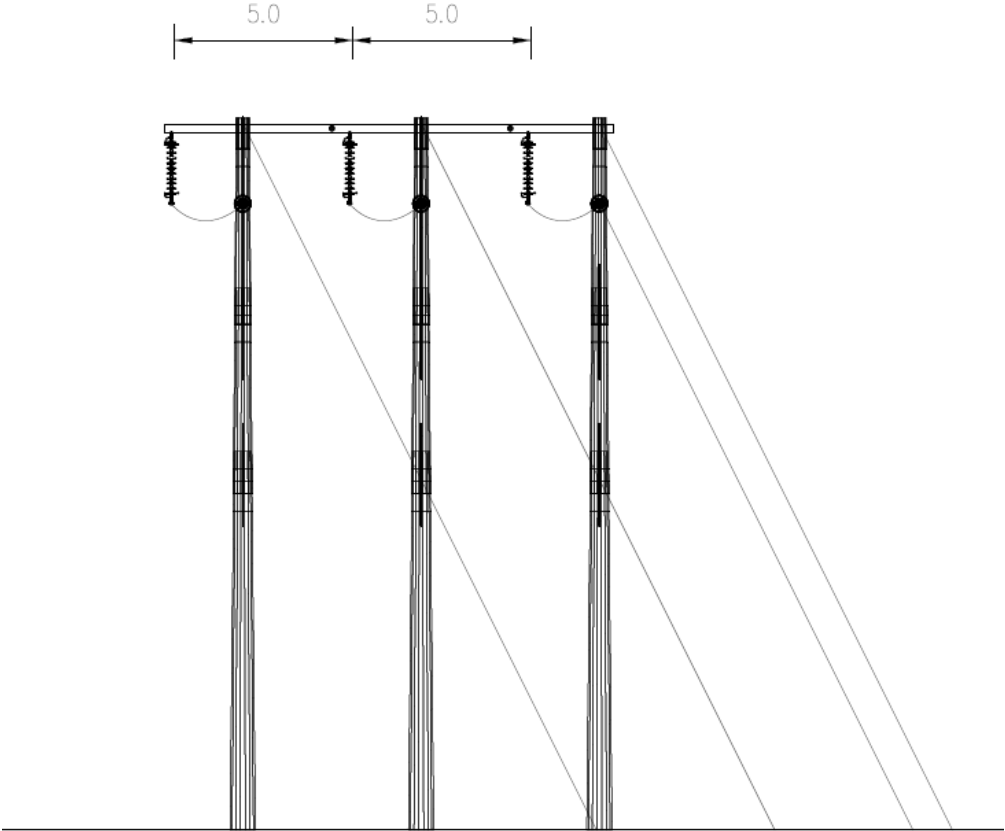

SIDESNITT

